

Product Brief



GRF6504

PHS RF CMOS Transceiver

GRF6504 Features

- ▶ True single-chip CMOS RF transceiver
 - Integrated LNA fully covering international 1.9 GHz PHS band
 - Fully integrated transmitter with programmable output power
 - Built-in channel selection filter
 - Fully integrated sigma-delta fractional-N frequency synthesizer including VCO and loop filters
 - Integrated I/Q up/down conversion mixer (1.2MHz of IF signals)
 - Programmable gain stage in Rx
 - Programmable output power in Tx
- ▶ Low-cost CMOS process technology with high performance
 - Allow under -104dBm min-sen (typ)
 - NF ~ 5.5dB, IIP3 ~ -15.5 dBm (typ.)
- ▶ Small form factor
 - 48pin 7mm x 7mm QFN
- ▶ Low power consumption
 - Tx: 50 mA at 2.8V, Rx: 100mA at 3.0V (typ)
- ▶ Fast switching time
 - Support seamless handover
 - Less than 25 us switching time: channel switching, Tx, Rx switching
- ▶ High performance ultra fast-lock PLL
 - Phase noise: -118dBc/Hz at 600kHz offset (typ)
 - Fast channel switching time: 20 us (typ)
- ▶ Analog base-band interface
 - Tx: Zero-IF I/Q differential
 - Rx: 1.2 MHz IF output
 - 3-wire program interface
 - RSSI output
- ▶ Supply voltage from 2.7V to 3.3V

GRF6504 Benefits

- ▶ Most cost-effective PHS RF transceiver
 - TRUE single-chip transceiver
 - Lowest BOM count < 50 components
- ▶ Extends frequency bands to support many nations including Japan, China, India, Mexico and Vietnam
- ▶ Outstanding performance per cost
 - Good sensitivity performance for mobile applications
 - Considerable RF performance margins for mobile applications
 - Longer battery-life
- ▶ Easy design and interface

Description

GCT's GRF6504 is a highly integrated monolithic RF transceiver for PHS applications based on GCT's industry proven CMOS RF technologies. This transceiver includes GCT's intrinsic low-IF (intermediate frequency) radio technology and requires a minimum number of external components, resulting in lower BOM cost and a smaller PCB area. GRF6504 is housed in 48-pin 7mmx7mm QFN package.

GRF6504 consists of a receiver, a transmitter, and PLL. The receiver section includes all functional blocks from the RF front-end to the base-band interface; LNA for 1.9GHz bands, down-conversion mixers, base-band filters, gain-controlled amplifiers and analog 1.2MHz IF interface. The transmitter section uses I/Q up-conversion architecture including analog base-band I/Q interface, up-conversion mixers and preamplifiers. The on-chip PLL includes VCO, a sigma-delta fractional-N frequency synthesizer, and built-in loop filters meeting fast and stable switching time requirements.

GRF6504

Applications

- ☐ PHS mobile devices

Simplified Application Block Diagram

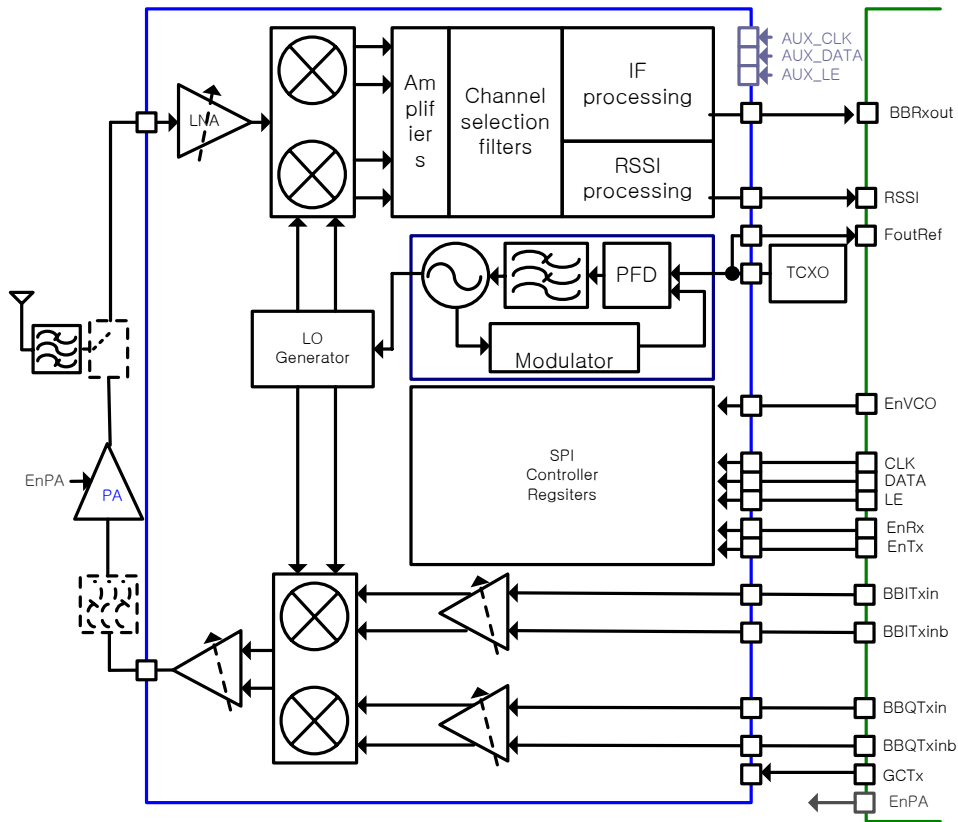

For more information, please contact us at:

Sales: contact_sales@gctsemi.com

Marketing: contact_marketing@gctsemi.com

GCT Semiconductor, Inc.

Headquarters

2121 Ringwood Avenue
San Jose, California 95131, USA

Tel. +1 408 434 6040

Fax. +1 408 434 6050

GCT Asia Pacific, Inc.

10F Specialty Construction Center
395-70 Shindaebang Dong, Dongjak Gu
156-714 Seoul, Korea

Tel. +82 2 2167 1100

Fax. +82 2 2167 1261

