

Advanced Bluetooth Stereo Solution



- **Silicon Solution**
 - Direct conversion CMOS RF Transceiver (GDML002)
 - Highly integrated SoC for Digital Audio Streaming (GDML202)
- **System Solution**
 - GCT Evaluation Board Kit
 - GCT Core Development Platform
 - PC-based Development Platform

Key Features

GDM1002 : Highly-Integrated CMOS Direct Conversion Radio Transceiver with BlueRF RXMODE2 Interface

- Class 2 and 3 (up to 10 meter range) compliant with Bluetooth Specification 1.2
- Fully-integrated single-chip transceiver with on-chip PLL, VCO, LNA, up/down converter, and digital GFSK modem
- Seamless interface to BlueRF RXMODE2 with unidirectional / JTAG serial interface or bidirectional/DBUS serial interface
- Up to -90dBm receiver sensitivity
- Superior adjacent channel selectivity of -6 dBC at 1-MHz offset from the carrier
- Supports dual reference clock frequency: 13/16MHz
- 40-pin QFN (6mm x 6mm) package

The family of GCT Bluetooth products is comprised of the 2.4GHz radio transceiver and single chip baseband controller for digital audio streaming. GCT provides the full Bluetooth protocol stack with optimized embedded code and profiles, along with a development kit that gives developers maximum flexibility to design, test, and debug software applications for GCT's chipsets.

Applications

- ▶ Multimedia USB Dongles, including Standard USB Bluetooth Interface
- ▶ USB Audio (using Audio data compression scheme with SBC Codec)
- ▶ USB storage device functions (GDM1202 features integrated NAND Flash controller)
- ▶ Stereo wireless speaker
- ▶ Portable MP3 players (WMA decoder, MP3 decoder)
- ▶ Portable MP3 CD Players (WMA/MP3 decoder, SBC Codec)
- ▶ VoIP phones (CTP Profile, H.323, ACL link)
- ▶ Handsfree boxes (echo cancellation)
- ▶ Wireless stereo headset



GDM1002



Part of the GCT Bluetooth product family, the GDM1002 is a low-cost, short-range, radio transceiver IC designed for Bluetooth links operating at 2.4 to 2.5GHz.

The GDM1002 integrates the complete receive and transmit components including PLL, VCO, LNA, up/down converter, channel select filters, and digital GFSK modem. Based on

GCT's proprietary direct conversion radio architecture, the device offers superior channel selectivity and fast automatic gain control.

Eliminating the need for external RF board components (such as external SAW filters and balun), the GDM1002 offers a greatly reduced total Bill of Materials (BOM). As a result, it meets the stringent Bluetooth requirement of "smallest form factor", and, since it is implemented in CMOS technology, the GDM1002 provides a low cost alternative for Bluetooth applications.

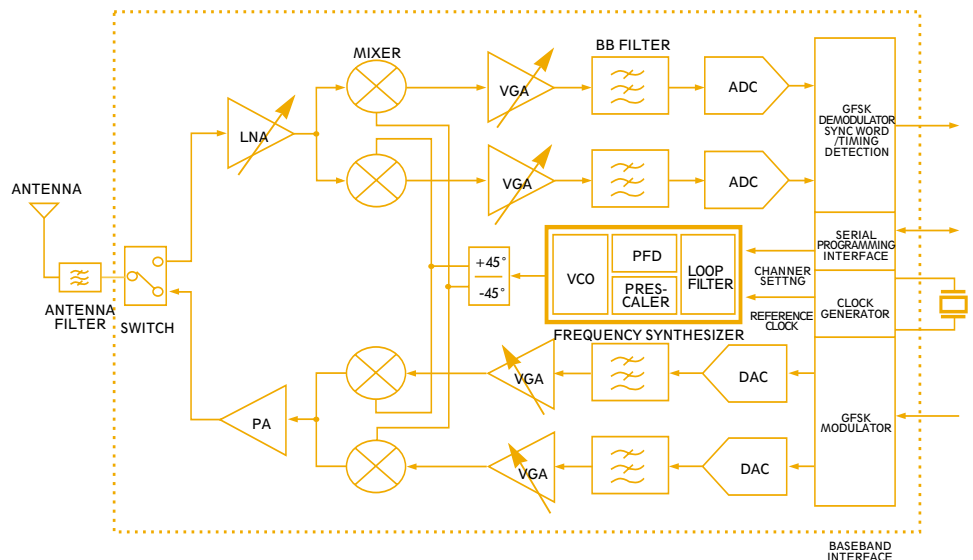

Implemented in CMOS technology, the GDM1202 is a single-chip Bluetooth baseband IC with an embedded digital signal processor (DSP). It is designed for use in audio-streaming Bluetooth applications, such as MP3 or WMA digital audio decoders.



When combined with the GDM1002 2.4GHz radio transceiver and external flash memory, the GDM1202 provides a fully-compliant Bluetooth radio solution, that is especially suited for digital audio streaming applications. The GDM1202 features a radio interface, a Bluetooth baseband for bit processing, an embedded 32-bit hybrid RISC/DSP, and standard peripheral interfaces.

GDM1202

- Designed for audio streaming applications, the GDM1202 allows high-quality audio content distribution and supports the Advanced Audio Distribution Profile (AADP) defined in Bluetooth.
- For a complete Bluetooth solution with minimal BOM configuration, the GDM1202 can be combined with the GDM1002 2.4-GHz radio transceiver, an external antenna, crystal, and 256KB of flash memory (for program code).
- An on-chip embedded processor based on GCT proprietary 128-MHz hybrid RISC/DSP technology has enough power to handle full-rate Bluetooth data/voice communications as well as computational intensive DSP applications.
- With 128Kbytes of internal SRAM, the GDM1202 supports both an on-chip Bluetooth stack [including LMP, L2CAP, SDP, AVDTP (A/V Distribution Transport Protocol) and AVCTP (A/V Control Transport Protocol)] and an audio application without additional external memory, thus providing a cost-effective, low-power solution.
- The GDM1202 uses GCT's optimized C compiler and intrinsic library functions to maximize the software developer's productivity. In addition, GCT provides a performance-optimized DSP library that accommodates several multimedia standards, such as MPEG audio decompression, Dolby Digital decompression, WMA, SBC, and speech codec.

Key Features

- Compliant with Bluetooth Specification 1.2
- Programmable seamless Bluetooth RF interfaces (such as BlueRF RXMODE2/3 uni/bi-directional and 3-wires RF interface) and programmable serial interfaces compatible with the GDM1002 radio transceiver ICs
- Standard UART, USB with device/host combo functions, 13/14bit 8kHz PCM/CVSD, and I2S two-channel external audio DAC interfaces
- Two or four-channel external PCM interface and I2S or SPDIF digital audio input/output interface support
- MMC/SDCard/SMC/CF Flash Card seamless interface support
- Integrated 8kHz PCM ADC and Stereo Digital AMP
- Proprietary USB can support Device/Hub and Host operation
- GCT's proprietary 128-MHz hybrid PiCOII-RISC and DSP embedded processor with 24-bit multiplication/48-bit accumulation resolution and 16kB instruction cache/128kB on-chip SRAM, sufficient to support several digital audio and speech codec such as MP3, AC3, and WMA
- On-chip implementation of Link Controller, Link Manager, HCI, L2CAP, RFCOMM, and A/V transport profiles for digital audio streaming applications within on-chip RAM only
- Support for micro-controller functions with four 2MB memory/IO devices and 59 GPIO ports
- Software development kit and source code licenses available for embedded stacks, and DSP firmware available for audio and speech standards
- Four level (Active, Sleep, Deep-sleep, Power-off) power management and RTC, watchdog timer supports
- Supports multiple reference clock frequencies : 12/13/16/19.2MHz
- 0.18um CMOS technology
- 144-pin fpBGA (10mm x 10mm) or 144-pin LQFP (20mm x 20mm) package

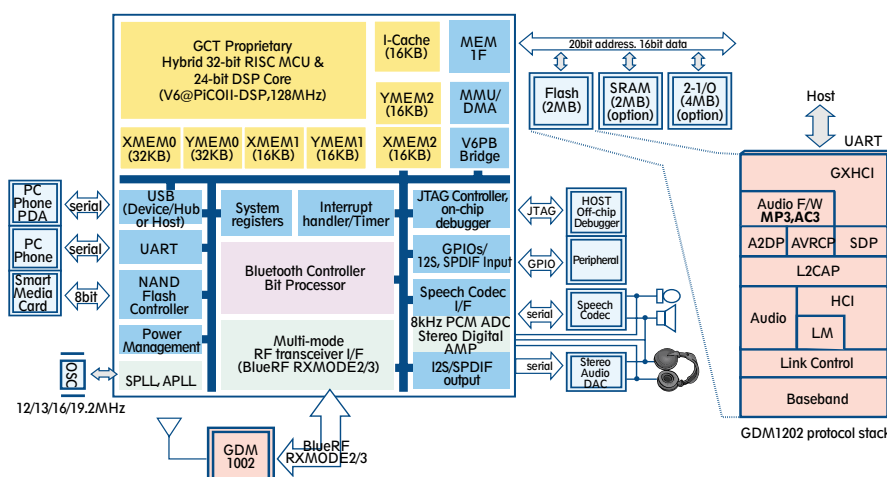

GCT Evaluation Board Kit (EBK)

System Solution In addition to its silicon solutions, GCT provides complete development platforms for implementing Bluetooth™ software and hardware applications. These platforms are designed for professional developers of applications that use host software and/or on-chip embedded software.

Evaluation Board Kit (EBK)

- The GCT Bluetooth evaluation board kit (EBK) is a system level kit that helps developers easily design and implement Bluetooth applications using GCT chipsets.
- For an optimal development environment, the GCT EBK features a JTAG and an RS-232 interface, allowing connection to a personal computer in order to download firmware as well as debug software and hardware.
- The EBK has a modular design scheme, which allows developers to easily compare and evaluate Bluetooth ICs with different functionality (such as RF-only or RF and baseband). They can also use the evaluation board to implement low-cost upgrades of system software.



GCT Bluetooth Evaluation Board Kit (EBK)



Key Features

- Incorporates all required features for implementing bluetooth functionality with the GDM1202 (GCT Bluetooth baseband ICs) and GDM1002 (GCT Bluetooth RF ICs) chipsets.
- Provides modular structure to enhance testability.
- Supports Class 2/3 (0dBm) and class 1 (+20dBm with external PA)
- Supports USB 1.1 specification (host/hub/device), High speed UART interface
- Supports MMC/SD, SmartMedia (NAND Flash) card interface and each file system.
- Provides stereo high quality audio CODEC including standard audio of Bluetooth.

GCT Bluetooth SOC(GDM1202) HW Features

Embedded Processor

32-bit RISC MCU

24-bit SIMD DSP Unit

128-MHz Operation

16-KB I-Cache
128-KB SRAM

JTAG Debugger

DMA

RTC

Power Management

Connectivity

Bluetooth Baseband
(BlueRF, BlueQ I/F)

USB 1.1 Device/Host

USB hub emulation

High-speed UART

SMC Controller

SD/CF/MMC Flash I/F

56-GPIOs

Multimedia

13-bit PCM Codec

Stereo Digital AMP

Multi-format PCM I/F

16/18/20/24-bit 12S
IN/OUT

SPDIF In/Out I/F

32/44.1/48KHz PLL

GCT Bluetooth SOC(GDM1202) SW Features

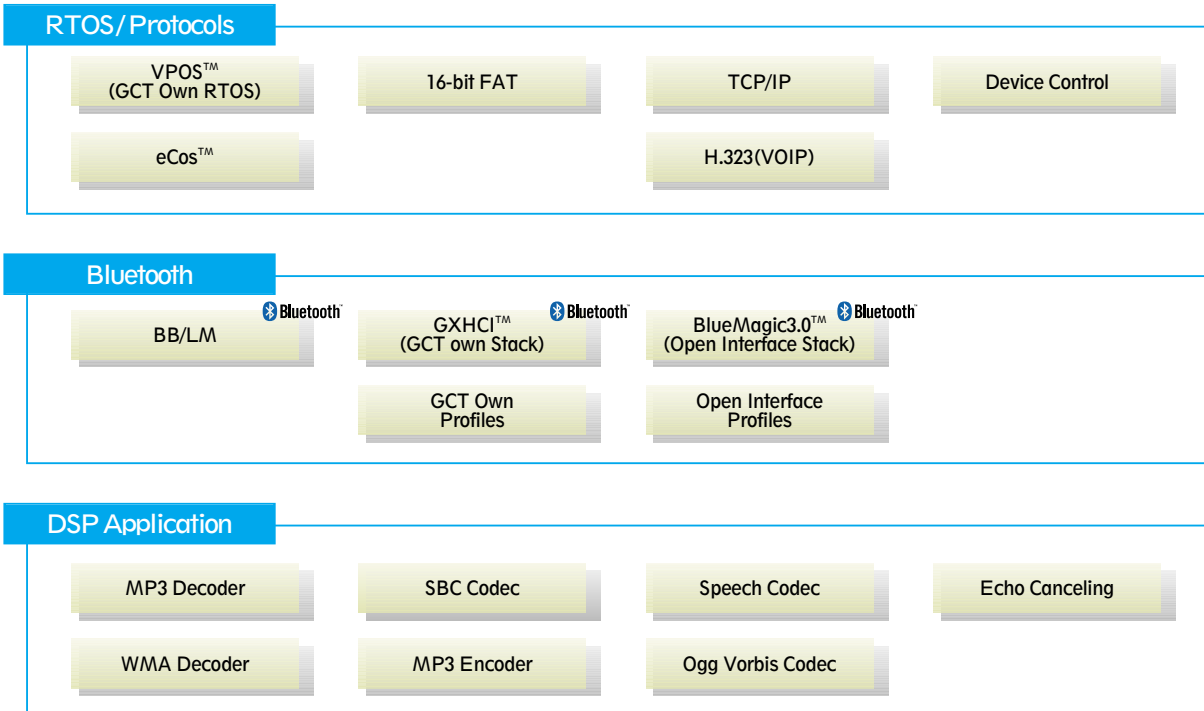

GCT provides an integrated development platform that enables users to fully access and evaluate GCT's chipsets and embedded stacks, thus accelerating implementation of customized applications.

VSDT: Vincent Software Development Tools

VSDT is an integrated software development toolset for users who want to develop their own embedded software running directly on GCT bluetooth chipsets. GCT ensures this "true application embedded" development by providing the following:

- ▶ Executables for firmware development, including
 - Vincent-gcc : C compiler
 - Vincent-g++ : C++ compiler
 - Vincent-as : assembler
 - Vincent-ld : Linker
 - Vincent-ar : Library archiver
 - Vincent-sim : Instruction-set simulator (ISS) with assemble level debugger
 - Vincent-gdb : source-level debugger
- ▶ Set of libraries for debugging with print function

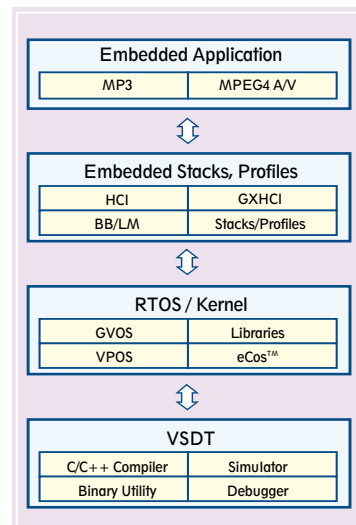

Key Features

- V6 (GCT proprietary embedded processor core) executable for program development.
- RTOS : VPOS or eCos with TCP/IP network suites.
- Embedded stacks, profiles, application HCI, GXHCI (GCT Extended HCI) firmware download/configuration.

GCoH: GCT Core Handler

- GCoH (GCT Core Handler) acts as a GUI-based communicator, providing both source and assembly level debugging with excellent firmware download and troubleshooting capabilities.



GCoH : GCT Core Handler

Features

- ▶ Standard JTAG interface
- ▶ Download binary files to/upload from Flash memory or SRAM
- ▶ Diagnostic operation of both evaluation board and GCT Bluetooth chipset
- ▶ Able to check GDM1202 core status in real time for real-time debugging
- ▶ Able to remotely debug GDM1202 binary file through GDM protocol

Bluetooth stack on Core

GCT provides embedded stacks and profiles running on various RTOS structures (such as VPOS or eCos) based on GVOS, GCT Virtual OS. GCT also supports third-party Bluetooth software stacks, including BlueMagic 3.0 from Open Interface Co. (BlueMagic 3.0 covers all of the features of the Bluetooth standard protocol stack and profiles as well as software requirements for many market applications.)

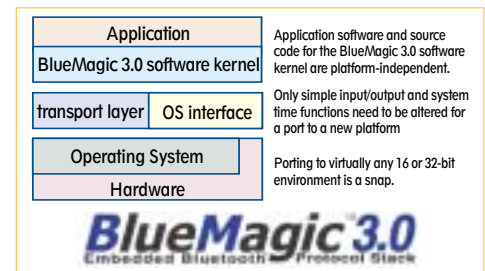

GXHCI : GCT Extended Host Controller Interface for Bluetooth

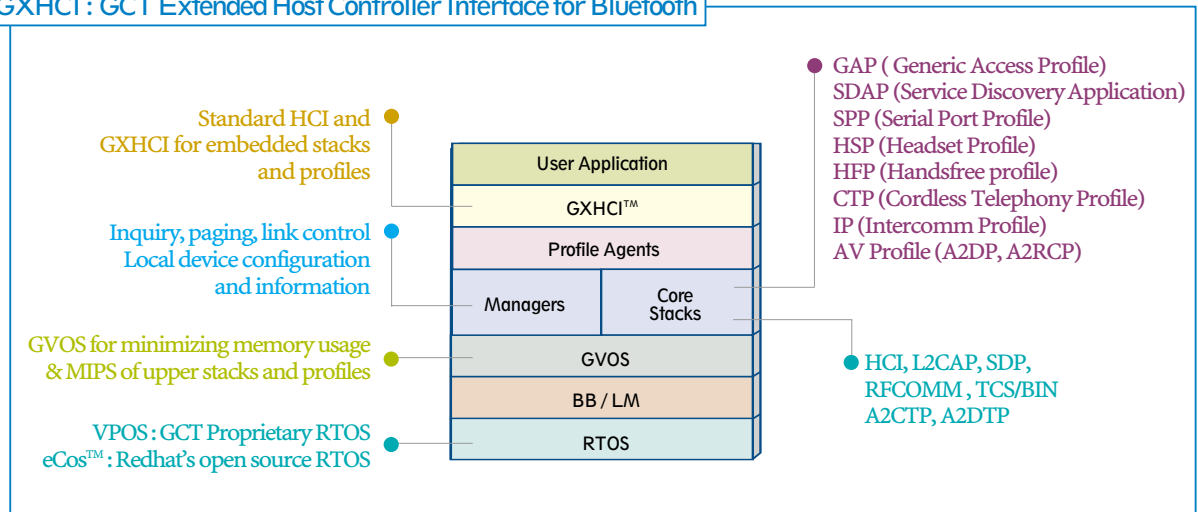

In addition to its core development products, GCT provides PC-based development platforms that help to fully implement Bluetooth applications. These products include BlueOne, BlueAudio, and BlueDisk.

BlueOne

BlueOne is an evaluation and development tool for host-side and embedded-target applications with several modes.

Key Features

- HCI & GXHCI packet generator and analyzer
- Macro executions of HCI commands by user script
- Data transfer test : BER measurement, file transfer



BlueOne

BlueAudio

BlueAudio is an evaluation program for audio streaming. It includes song management and play control for use with the GCT Bluetooth evaluation board kit (EBK).



BlueAudio

BlueDisk

BlueDisk is an evaluation program for portable MP3 player applications. It acts as a station program running on a PC, controlling storage components such as memory cards or NAND flash memory.



BlueDisk



www.gctsemi.com

Head Office

2121 Ringwood Avenue San Jose CA 95131
T. 408 434 6040 F. 408 434 6050

GCT Asia Pacific, Inc.

Financial News B/D 5F 24-5, Yoido Dong,
Youngdeungpo Gu, Seoul 150-877 Korea
T. 82 2 2167 1100 F. 82 2 2167 1261

GCT Research, Inc.

Financial News B/D 4F 24-5, Yoido Dong,
Youngdeungpo Gu, Seoul 150-877 Korea
T. 82 2 2167 1170 F. 82 2 2167 1290

©2003 GCT Semiconductor, Incorporated.

All rights reserved. GCT Semiconductor, Inc. is a registered trademark. And other trademarks mentioned in this document are property of their respective owners. Information in this document is preliminary in nature and subject to change without notice.

K-1124-03-PBGDM1002-008